

Annual Control Report (EMFAF)	3
Workflow.....	4
Create an Annual Control Report (EMFAF).....	5
Record/Edit the Annual Control Report (EMFAF)	8
General.....	8
Version Information.....	9
Officials in Charge	9
History	11
Documents.....	12
Uploading & Sending Documents	13
Sending an unsent non-integral document.....	16
Deletion of an unsent document	17
Observations.....	18
Programmes covered	19
Annex 1	20
Annex 2	25
Annex 3	27
Annex 4	29
Annex 5	32
Validate the Annual Control Report (EMFAF).....	34
Prepare the Annual Control Report (EMFAF) for send to EC	39
Send the Annual Control Report (EMFAF)	41
Return the Annual Control Report (EMFAF) for modification by MS.....	42
Delete the Annual Control Report (EMFAF)	44
Cancel the Annual Control Report (EMFAF)	46
Create a New Version of the Annual Control Report (EMFAF)	48

Annual Control Report (EMFAF)

PURPOSE

This document describes the actions related to the Annual Control Report (ACR) procedure as described in point (b) of Article 77(3), and Annex XX of the CPR Regulation. The Annual Control Report needs to be submitted together with the assurance package before the 15 of February of each year, starting from 2023.

REGULATIONS

More detail regarding the regulation of the Annual Control Report can be found in the "[About SFC2021](#)" section of the portal.

ROLES

Roles involved in the Annual Control Report are:

MS Audit Authority (MSAA)	Record Annual Control Report Upload Annual Control Report Documents Consult Annual Control Report Delete Annual Control Report Validate Annual Control Report Prepare Annual Control Report for send to EC Send Annual Control Report Return Annual Control Report by MS for modification Cancel Annual Control Report Create New Version of an Annual Control Report
MS Managing Authority (MSMA) Body entrusted with the Accounting Function (MSAF)	Consult Annual Control Report

FUNDS

EMFAF

Workflow

This section shows the lifecycle to create and manage an Annual Control Report (EMFAF).

Click [here](#) to see the Annual Control Report workflow diagram in high resolution.

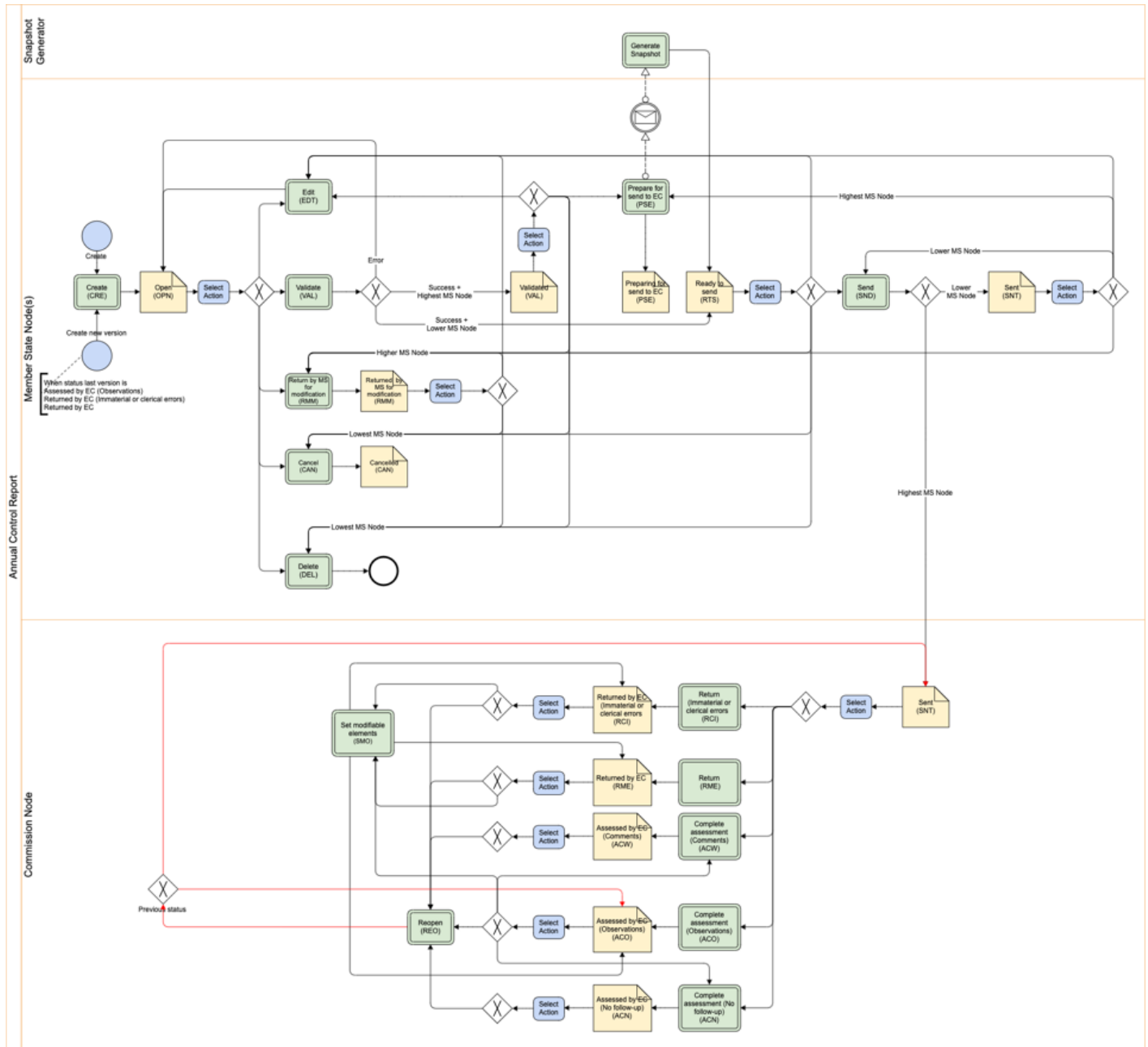

Create an Annual Control Report (EMFAF)

REMARK	<p>The User is an identified User and has the role of MS Audit Authority with Update rights (MSAAu).</p> <p>When creating a new Annual Control Report, it doesn't yet exist (based on title and original node).</p>
---------------	---

1. To create the Annual Control Report, go to the **AUDIT** menu and select the **ANNUAL CONTROL REPORT (EMFAF)** option:

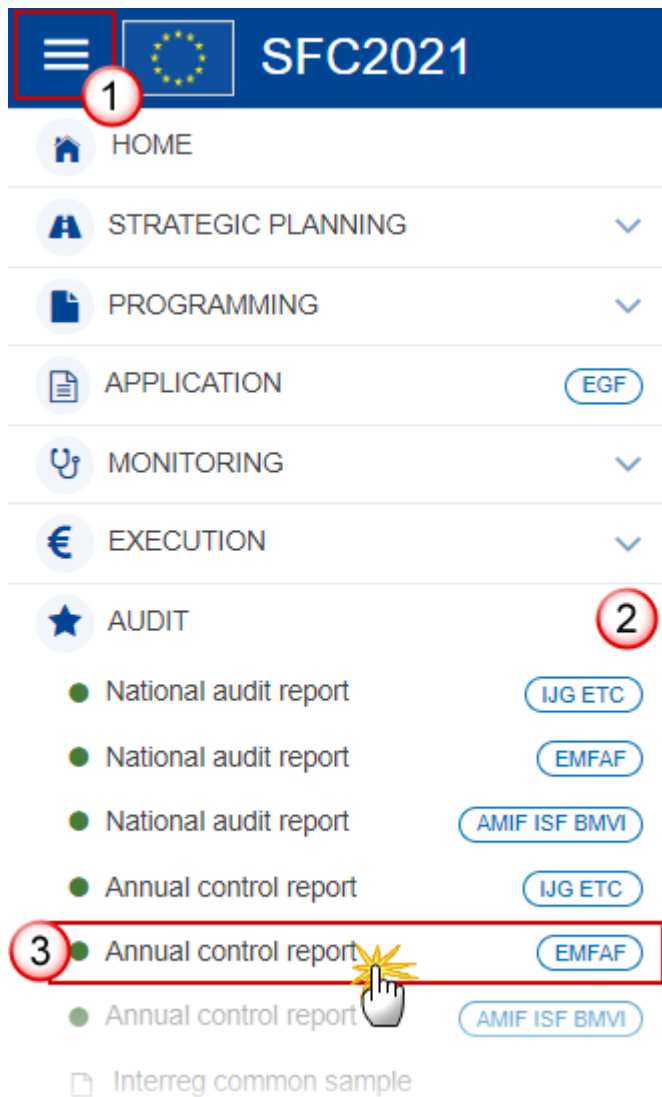

2. In the search screen click on the **CREATE** button to create a new Annual Control Report:



You are redirected to the Annual Control Report Creation Wizard:

3. Enter or select the following information:

(1) Enter the *Title*.

There can be multiple Annual Control Report versions with a different Title for an Accounting Year. Only the first working version for a specific Title and Year is created via the creation wizard.

(2) Select the *Accounting Year*.

The Annual Control Report is always referring to an Accounting Year. Creation of the Annual Control Report for an Accounting Year will only be enabled after the due date of the Final Payment Application

of that Accounting Year. The Accounting Year list will therefore contain all Accounting Years with a Final Payment Application due date < current date.

(3) Select the *Source language*.

The Source language list contains all official languages of the Member States.

(4) Click on **CREATE**.

The status of the Annual Control Report is **OPEN**.

REMARK	<p>The version and work version number are automatically provided by the system on "Create new Annual Control Report". The version number is the Accounting Year, and the work version number is 0.</p> <p>On Create, when the preconditions are met, the initial Annual Control Report structure is created and a Table of Content (ToC)/Navigation Tree is presented, so the user can continue to populate the structured data of the Annual Control Report.</p>
---------------	--

Record/Edit the Annual Control Report (EMFAF)

REMARK	<p>The User is an identified User and has the role of MS Audit Authority with Update rights (MSAAu).</p> <p>When editing a version of the Annual Control Report, its status is OPEN, VALIDATED, READY TO SEND, RETURNED BY MS FOR MODIFICATION at the level of the Member State and currently resides on the User's Node.</p> <p>As long as no Programmes have been added to the Annual Control Report, any MS User having only one of the Fund permissions is allowed to modify the object.</p> <p>When Programme(s) have been added, the User should have Update rights on all Annual Control Report Programme relevant Funds.</p>
---------------	---

General

This section includes the header data to identify the main characteristics of the Annual Control Report.

Version Information

NOTE	<p>The Version Information contains information on the identification and status of the Annual Control Report Version like the Title, the Version Number, the Date of final audit report, the Source language, the Last modified date, the Status and the Node where it currently resides.</p> <p>When the Status is ANALYSED BY EC WITH ASSURANCE PACKAGE then a link to the Annual Control Report (ACR) documents Table of Content will be shown, containing the Ares number of the document chosen as reference to the ACR.</p> <p>The Date of the final report of the NAR will be used to later import the NAR information in the ACR and it must be greater or equal to the current date.</p> <p>The Title should be unique per original node.</p>
-------------	---

Click on the **EDIT** button to edit the Version information if needed:



The screenshot shows a web interface for 'Version information'. On the left is a 'Table of Contents' sidebar with a search bar and a list of items: General, Version information (selected), Officials in charge, History, Documents, Observations, Programmes covered, Annex 1, Annex 2, Annex 3, Annex 4, and Annex 5. The main content area is titled 'Version information' and includes an 'Edit' button (highlighted with a red box and a hand cursor) and an 'OPEN' button. Below this is a table with the following data:

Version	Last modified	Current node
2021.0	14/03/2023, 11:49	España

Below the table are two input fields: 'Title' with the value 'ACR - Test SG' and 'Source language' with the value '[ES] Spanish'. Underneath is a section titled 'MODIFIABLE ELEMENTS IN THIS VERSION' containing two checked checkboxes: 'Annual control report structured data' and 'Annual control report documents'. At the bottom left of the interface, it says 'No validation result available'.

Officials in Charge

NOTE	<p>Officials in Charge can be updated at any time, independent from the status of the Annual Control Report.</p> <p>Commission Officials (email domain "ec.europa.eu") can only be created/updated/deleted by Commission Users.</p>
-------------	---

- Click on the **ADD** button  to add a new official in charge.
- Clicking on the **EDIT** icon  of a row will allow you to modify the information of this official.
- Clicking on the **DELETE** icon  of a row will allow you to delete the official in charge selected.

1. Click on the **ADD** button to add a new Official in Charge:

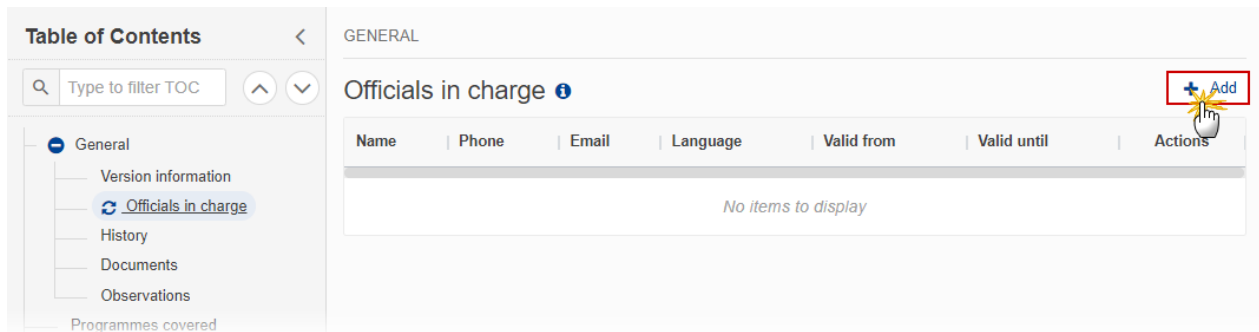

The screenshot shows a web interface for managing 'Officials in charge'. On the left is a 'Table of Contents' sidebar with a search bar and a list of menu items: General, Version information, Officials in charge (highlighted), History, Documents, Observations, and Programmes covered. The main content area is titled 'GENERAL' and 'Officials in charge'. It features a table with the following columns: Name, Phone, Email, Language, Valid from, Valid until, and Actions. The table body is empty, displaying the text 'No items to display'. A red rectangular box highlights the '+ Add' button located in the top right corner of the table's header area.

The Edit details pop-up window appears:

Officials in charge ⓘ

Add official

Name * 1

Some One

Email * 2

@ test@test.com

Phone 3 Language 4

Valid from Valid until 5

Cancel Save 6

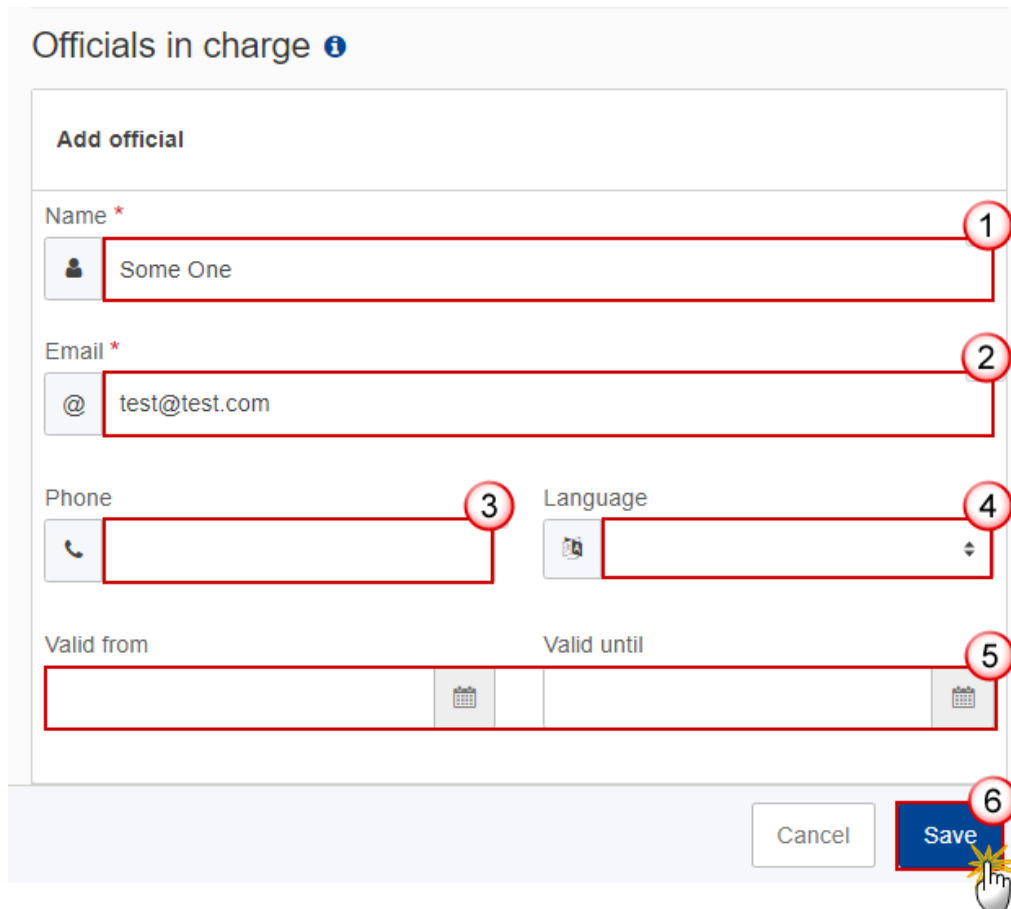

2. Enter or select the following information:

(1) Enter the *Name*.

(2) Enter the *Email*.

The format of the Email address will be validated by the system and should be unique.

(3) Enter the *Phone* number.

(4) Select the *Language*.

(5) Enter the *Valid from* and *Valid until* dates.

The *Valid until* date should be greater than the *Valid from* date.

(6) Click on **SAVE** to save the information.

History

This section shows all the actions that have been taken on the Annual Control Report since it was created, for example:

Documents

NOTE	The Documents list shows all documents uploaded against this version of the Annual Control Report by Member State and by Commission. Member State Users see all their own Documents and the sent Commission Documents. Commission Users see all their own Documents, unsent Integral Member State Documents and sent Member State Documents.
-------------	---

The following documents will be foreseen:

Description	Internal Code	Non-Integral (1)	Integral (2)	System (3)	Required (4)
MS reply to Commission observations	ACR.MRO	X			
Calculation random sample selection + total error rate (Excel format)	ACR.CRS		X		X(5)
Calculation of total error rate (Spreadsheet format)	ACR.TER		X		X(6)
Calculation total residual error rate (Spreadsheet format)	ACR.TRR		X		X(7)

Snapshot of data before send	SNP.ACRSNT		X	X	X
Annual Control Report	ACR.ACR		X		X(8)
Other Member State document(9)	ACR.OM	X			

(1) Document can be sent at any time

(2) Document will be automatically sent when the Object is sent

(3) Document automatically created by the system

(4) Document required in the system before a next action can be executed

(5) Only on first working version and only from Accounting Year 2022 (2022-2023) onwards

(6) Only on first working version and only from Accounting Year 2022 (2022-2023) onwards





(7) Only on first working version and only from Accounting Year 2022 (2022-2023) onwards

(8) When no previous version or when requested in previous version

(9) Allow to create and send only when ACR covers at least one Programme

Uploading & Sending Documents

Multiple documents can be uploaded in the Annual Control Report.

- Clicking on the **ADD** button  will open a pop-up window allowing you to add a new document type with attachments.
- Selecting a document row and clicking on the **VIEW** icon  will allow you to view the document information.
- Selecting a document row and clicking on the **EDIT** icon  will allow you to modify the document information. If a document of type 'Other Member State Document' must be sent, you can select the edit icon in order to send the document.
- Selecting a document row and clicking on the **DELETE** icon  will allow you to delete the document and all attachments.

REMARK	<p>Integral Documents (Official Proposal etc) are only sent - together with the encoded data – once the Annual Control Report is sent to the EC.</p> <p>Referential/non-integral Documents (ie. 'Other Member State Document') can be sent at any time independently of the status of the Annual Control Report.</p> <p>The 'Other Member State Document' type demands a manual submission (they are NOT sent automatically when the object is sent to the EC).</p> <p>A non-integral document is only visible to the Commission when the SENT DATE is visible.</p>
---------------	--

1. Click on the **ADD** button to add a new document:

The screenshot shows a web interface with a 'Table of Contents' sidebar on the left and a main content area. The sidebar includes sections like 'General', 'Version information', 'Officials in charge', 'History', 'Documents', 'Observations', 'Programmes covered', and 'Annex 1-5'. The main content area is titled 'GENERAL' and 'Documents annexed'. It features a search bar and a table of documents. The 'ADD' button is highlighted with a red box and a mouse cursor.

Title	Document type	Document date	Local reference	Commission reference	Files	Sent date	Sent by	Actions
ACR doc	Annual control report	30/01/2023			1			

MANDATORY DOCUMENTS ALREADY SUBMITTED AGAINST PREVIOUS VERSIONS

Title	Document type	Previous version	Document date	Local reference	Commission reference	Files	Sent date	Sent by
<i>No items to display</i>								

No validation result available

The Edit document details pop-up window appears:

Document

Document title *

Document type *

Document date *

Local reference

ATTACHED FILES



Title	Type	Language	File / Upload	Action
-------	------	----------	---------------	--------

2. Enter or select the following information:

(1) Enter a *Document title* for your Document.

(2) Select a *Document type*.

(3) Enter a *Document date*.

The system automatically fills the field with today's date, but this can be modified.

(4) Enter a *Local reference*.

(5) Click on the **ADD** button to add a new attachment:

- You can add multiple attachments by clicking on the **ADD** button.
- You can remove unwanted attachments by selecting the attachment and clicking on the **REMOVE** button.

The **Attached files** window becomes editable:

ATTACHED FILES

Title	Type	Language	File / Upload	Action
ACR	Main	en. English	Browse File uploaded!	

Cancel Save

3. Enter or select the following information:

(1) Enter a *Title* for your attachment.

(2) Select the *Type* of the document.

It is possible to select from these 4 types: Annex, Cover Letter, Main or Translation.

(3) Select the *Language* of the document.

(4) Click on **BROWSE** to select the file that you want to add as an attachment.

(5) After the attachments are uploaded click on **SAVE**.

REMARK	Integral document types will only display the SAVE button and will be sent when the Annual Control Report is sent to the Commission. Non-integral document types (such as 'Other Member State Documents') will display the SAVE button and a SAVE & SEND button, and must be sent independently of the Annual Control Report.
---------------	--

Sending an unsent non-integral document

1. Once the document and attachment(s) have been uploaded click on the **EDIT** icon in the row containing the unsent document:

The screenshot shows a web interface for managing documents. On the left is a 'Table of Contents' sidebar with a search bar and a list of categories: General, Version information, Officials in charge, History, Documents, Observations, and Programmes covered. The main area is titled 'GENERAL' and 'Documents annexed'. Below this is a sub-section 'DOCUMENTS ANNEXED TO THIS VERSION' with an '+ Add' button. A table lists the documents with columns: Title, Document type, Document date, Local reference, Commission reference, Files, Sent date, Sent by, and Actions. One document is listed: 'ACR Other Member State document' with a date of '08/02/2023' and '1' file. The 'Actions' column for this document shows three icons: a pencil (EDIT), a trash can, and an eye. The pencil icon is highlighted with a red box and a mouse cursor.

2. Click on **SAVE & SEND** to send the document to the Commission:

ATTACHED FILES

+ Add

Title	Type	Language	File / Upload	Action
ACR	Main	en. English	ACR.docx	 

Cancel

Save

Save & Send



REMARK

The **SAVE & SEND** button will only be shown for documents which are not integral part of the Object and after at least one attachment was added.

Deletion of an unsent document

REMARK

Only unsent documents can be deleted.

1. In the row of a previously uploaded unsent document click on the **DELETE** icon to delete the document and associated attachments:

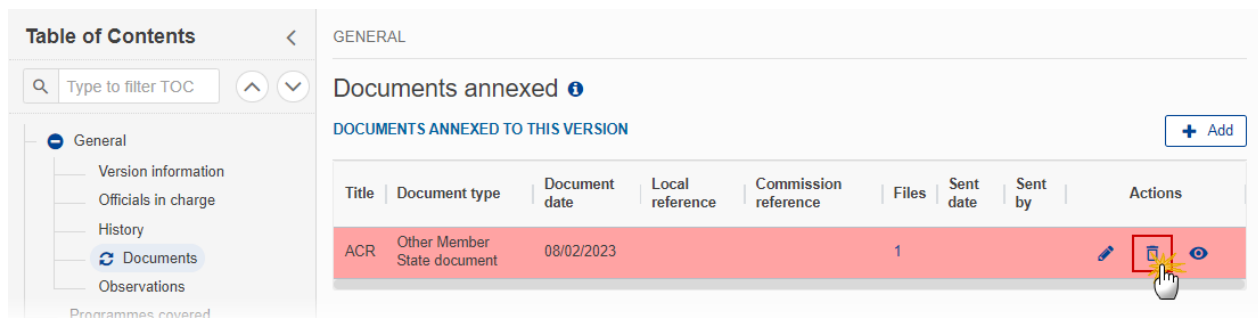





Table of Contents <

GENERAL

Documents annexed ⓘ

DOCUMENTS ANNEXED TO THIS VERSION + Add

Title	Document type	Document date	Local reference	Commission reference	Files	Sent date	Sent by	Actions
ACR	Other Member State document	08/02/2023			1			  

A confirmation window appears:

Delete document



Are you sure you want to delete the document with title "ACR doc"? This action cannot be undone.

Cancel

OK



2. Click on **OK** to confirm deletion. Click on **CANCEL** to return to the document section.

Observations

NOTE	<p>This section is used to provide any relevant information to the Annual Control Report. It can be used as a type of 'chat' between the Member State and Commission.</p> <p>All Users who have Read permission on the Annual Control Report will be able to read all Observations in the conversation.</p> <p>All Users who have Update permission on the Annual Control Report will be able to send an observation and participate in the conversation.</p> <p>All observations are kept against the specific version of the Annual Control Report.</p> <p>The observation is added below the Observations box and includes the username, the date and time of the post.</p>
-------------	--

1. Click on the **ADD** button to add an observation:

Table of Contents <

GENERAL

Observations ⓘ

+ Add

No items to display

General

- Version information
- Officials in charge
- History
- Documents
- Observations**
- Programmes covered
- Annex 1

The Add new observation screen appears:

Observations ⓘ

Add new observation

Should I add the extra information as a document?

Cancel Save

1. Enter the following:

(1) Enter an observation.

(2) Click on **ADD** to save the information.

Programmes covered

1. Click on the **EDIT** button to select the Programmes covered by the Annual Control Report:

Table of Contents <

PROGRAMMES COVERED ⓘ

Type to filter TOC

General

Programmes covered

Annex 1

Annex 2

Annex 3

Annex 4

Annex 5

No programmes added yet

Edit

The Edit details pop-up window appears:

PROGRAMMES COVERED ⓘ

Select an option or type to filter options ▼*

This field is required

Cancel Create

2. Select the following:

(1) Select the *Programmes covered*.

The CCI list contains all adopted EMFAF Programmes for which the User has read permission, and which contain a Fund for which the User is registered, and the User has ACR update permission on all Funds of that Programme.

At least one Programme must be selected. This will be enforced by validation rule ACR_004.

(2) Click on **SAVE** to save the information.

Annex 1

1. Click on the **ADD** button to enter the values in the table or on the three dots to **IMPORT FROM NAR** (see further down):

Table of Contents <

ANNEX 1 - RESULTS OF SYSTEM AUDITS ⓘ

+ Add

Type to filter TOC ↑ ↓

- > General
- Programmes covered
- Annex 1
- Annex 2
- Annex 3
- Annex 4
- Annex 5

No validation result available

CCI(s)	Fund(s)	Audited entity	Title of the audit
No Rows To Show			

← →

The Edit details pop-up window appears:

ANNEX 1 - RESULTS OF SYSTEM AUDITS

CCI(s) *

Select one or more programmes

1

Fund(s) *

Select one or more funds

2

Audited entity *

3

Entity type *

Select an entity type

4

Title of the audit *

5

Date of final audit report *



6

Requirements

Key requirement

KR1 - Appropriate separation of functions and written arrangements for reporting, supervising and monitoring of delegated tasks to an intermediate body

Category *

1. Works well. No or only ...

8

Select a requirement

7

Overall assessment (Category)

Select a category

9

Comments

10

Cancel

Save

11

2. Select or enter the following:

(1) Select the CCI(s).

The list of CCI contains all Programmes covered by this ACR. At least one should be selected.

(2) Select the *Fund(s)*.

The list of Funds contains all Funds covered by the Programmes covered by this ACR. At least one should be selected.

(3) Enter the *Audited entity*.

(4) Select the *Entity type*.

The list of Entity Types contains the Programme Authority Types “Managing Authority” and “Body (other than Managing Authority) carrying out the accounting function”.

(5) Enter the *Title of the audit*.

(6) Enter the *Date of final audit report*.

(7) Select a *requirement*.

The list of selectable Key Requirements contains all Key Requirements valid for the selected Entity Type as defined in Table 1 of Annex XI of the CPR.

(8) Select a *Category* for the Key requirement.

When a Key Requirement is selected, the selection of a Category, as defined in Table 2 of Annex XI of the CPR, becomes mandatory.

(9) Select a *Overall assessment (Category)*.

The Overall assessment list contains all Categories as defined in Table 2 of Annex XI of the CPR.

(10) Enter *Comments* if necessary.

(11) Click on **SAVE** to save the information.

REMARK	Imported records can be edited/deleted or new ones can be added. CCI, Fund, Audited entity, Entity type, Title of the audit and Date of the final audit report are mandatory.
---------------	--

It is also possible to import data from the submitted National Audit Report:

1. Click on the three dots and then on the **IMPORT FROM NAR** button:

The Edit details pop-up window appears:

2. Select or enter the following:

(1) Select a date to *Filter national audit reports with a final audit report date after*.

The list of available NARs contains all NARs submitted to the Commission and referring to one of the Programme CCIs covered by the ACR. This list can be restricted by a filter on the “Date of final audit report” of the NARs, showing only those NARs with a “Date of final audit report” after the filter date.

(2) Select the *National audit reports - Date of the final audit report*.

The list of CCIs covered by the NAR will be restricted to those covered by the ACR.

(3) Click on **SAVE** to save the information.

REMARK	When importing, the NAR records will be added, when not yet existing in the ACR, based on the CCI(s)/Fund(s)/Authority type/Audited entity/Title of the audit/Date of final audit report combination.
---------------	---

Annex 2

1. Click on the **ADD** button to enter the values in the table:

Table of Contents <

🔍 Type to filter TOC

- General
- Programmes covered
- Annex 1
- Annex 2**
- Annex 3
- Annex 4
- Annex 5

No validation result available

ANNEX 2 - RESULTS OF AUDITS OF OPERATIONS ⓘ

+ Add

CCI(S)	Funds	Amount in euros corresponding to the population from which the sample was drawn	Expenditure in reference to the accounting year audited for the random sample	Amount of irregular expenditure in random sample	Total error rate	Corrections implemented as a result of the total error rate	Residual total error rate	Other expenditure audited	Amount of irregular expenditure in other expenditure audited
		(A)	Amount (B.1) % (B.2)	(C)	(D)	(E)	(F)	(G)	(H)
No items to display									

The Edit details pop-up window appears:

ANNEX 2 - RESULTS OF AUDITS OF OPERATIONS

CCI(S) *

Select a CCI

1

Funds *

Select a fund

2

A. Amount in euros corresponding to the population from which the sample was drawn *

3

B. Expenditure amount in reference to the accounting year audited for the random sample *

4

C. Amount of irregular expenditure in random sample *

5

D. Total error rate *

6

E. Corrections implemented as a result of the total error rate *

7

F. Residual total error rate *

8

G. Other expenditure audited *

9

H. Amount of irregular expenditure in other expenditure audited *

10

11

Cancel

Save



2. Select or enter the following:

(1) Select the *CCI(s)*.

The list of selectable CCIs contains all Programmes covered by this ACR. At least one should be selected.

(2) Select the *Fund(s)*.

The list of selectable Funds contains all Funds covered by the Programmes covered by this ACR. At least one should be selected.

(3) Enter the *Amount in euros corresponding to the population from which the sample was drawn*.

(4) Enter the *Expenditure amount in reference to the accounting year audited for the random sample*.

(5) Enter the *Amount of irregular expenditure in random sample*.

(6) Enter the *Total error rate*.

(7) Enter the *Corrections implemented as a result of the total error rate*.

(8) Enter the *Residual total error rate*.

(9) Enter the *Other expenditure audited*.

(10) Enter the *Amount of irregular expenditure in other expenditure audited*.

(11) Click on **SAVE** to save the information.

Annex 3

NOTE	The Documents list shows all documents belonging to the “Calculation random sample + total error rate + total residual error rate” document group, uploaded by the Member State against this version of the Annual Control Report and uploaded in previous versions. Only documents of this Document Group can be uploaded here.
-------------	--

1. Click on the **ADD** button to add a document:

ANNEX 3 - CALCULATION RANDOM SAMPLE SELECTION + TOTAL ERROR RATE ⓘ									
DOCUMENTS ANNEXED TO THIS VERSION									
Title	Document type	Document date	Local reference	Commission reference	Files	Sent date	Sent by	Actions	
No items to display									
MANDATORY DOCUMENTS ALREADY SUBMITTED AGAINST PREVIOUS VERSIONS									
Title	Document type	Previous version	Document date	Local reference	Commission reference	Files	Sent date	Sent by	
No items to display									

[+ Add](#)

The Edit details pop-up window appears:

Document

Document title * 1

Document type * 2 Document date * 3

Local reference 4

ATTACHED FILES 5

Title	Type	Language	File / Upload	Action
No items to display				

2. Select or enter the following:

(1) Enter a *Document title* for your Document.

(2) Select the *Document type*.

The Document type list will contain three types: Calculation random sample selection, Calculation of total error state and Calculation total residual error rate.

(3) Enter a *Document date*.

The system automatically fills the field with today's date, but this can be modified.



(4) Enter a *Local reference*.

(5) Click on the **ADD** button to add a new attachment:

- You can add multiple attachments by clicking on the **ADD** button.
- You can remove unwanted attachments by selecting the attachment and clicking on the **REMOVE** button.

The **Attached files** window becomes editable:

ATTACHED FILES + Add

Title	Type	Language	File / Upload	Action
Integral doc	Main	English	Browse Choose file	 

Cancel **Save** 

3. Enter or select the following information:

(1) Enter a *Title* for your attachment.

(2) Select the *Type* of the document.

It is possible to select from these 4 types: Annex, Cover Letter, Main or Translation.

(3) Select the *Language* of the document.

(4) Click on **BROWSE** to select the file that you want to add as an attachment.

(5) After the attachments are uploaded click on **SAVE** or **SAVE & SEND**.

Annex 4

1. Click on the **ADD** button to enter the values in the table:

Table of Contents <

ANNEX 4 - AUDIT FINDINGS ⓘ

+ Add

Q Type to filter TOC ^ v

- General
- Programmes covered
- Annex 1
- Annex 2
- Annex 3
- Annex 4
- Annex 5

No validation result available

Category	Sub-category	Fund	Cases of suspected fraud	Cases of gold-plating	Frequency (Number of cases)	Amount of the irregularities (in total costs and €)	Actions
No items to display							

The Edit details pop-up window appears:

ANNEX 4 - AUDIT FINDINGS

Sub-category * 1

Select sub-category v

Funds * 2

Select a fund v

Cases of suspected fraud * 3

Cases of gold-plating * 4

Frequency (Number of cases) * 5

Amount of the irregularities (in total costs and €) * 6

Comments * 7

Cancel Save 8



2. Select or enter the following:

- (1) Select the *Sub-category*.
- (2) Select the *Funds*.
- (3) Enter the *Cases of suspected fraud*.
- (4) Enter the *Cases of gold-plating*.
- (5) Enter the *Frequency (Number of cases)*.
- (6) Enter the *Amount of the irregularities (in total costs and €)*.
- (7) Enter the *Comments*.

The Comments field is only shown for sub-categories with 'Other', is mandatory and has a maximum length of 3000 characters.

(8) Click on **SAVE** to save the information.

Annex 5

NOTE	A card will be automatically shown for each Programme covered by the ACR (selected in section Programmes covered).
-------------	--

1. Click on the **EDIT** button to select the EPA status:

The screenshot shows a web application interface. On the left is a 'Table of Contents' sidebar with a search bar and a list of sections: General, Programmes covered, Annex 1, Annex 2, Annex 3, Annex 4, and Annex 5 (which is selected and highlighted in blue). The main content area displays the title 'ANNEX 5 - OVERVIEW OF THE APPLICATION OF ENHANCED PROPORTIONATE ARRANGEMENTS (ARTICLES 83 - 85 CPR) WITH REGARD TO THE PROGRAMME(S) COVERED BY THE ANNUAL CONTROL REPORT'. Below the title is a card for '2021IT14MFPR001 - National Operational Program funded by the European Maritime, Fisheries an...'. The card contains the text 'EPA status not yet selected' and an 'Edit' button with a pencil icon, which is highlighted by a red box and a mouse cursor.

The Edit details pop-up window appears:

ANNEX 5 - OVERVIEW OF THE APPLICATION OF ENHANCED PROPORTIONATE ARRANGEMENTS (ARTICLES 83 - 85 CPR) WITH REGARD TO THE PROGRAMME(S) COVERED BY THE ANNUAL CONTROL REPORT

2021IT14MFPR001 - National Operational Program funded by the European Maritime, Fisheries and Aquaculture Fu...

EPA Status *

Select an EPA Status 

Cancel Save 

2. Select the following:

(1) Select the *EPA Status*.

The “EPA status” list contains all EPA statuses, valid for the CCI:

- EPA status 1: CCI is not yet used in Annex 5 of any sent ACR of the previous accounting year or is used but in EPA status 6 or 7,
- EPA status 2: CCI is already used in Annex 5 of any sent ACR of the previous accounting year and is not in EPA status 4, 5, 6 or 7,
- EPA statuses 3 to 6: CCI is already used in Annex 5 of any sent ACR of the previous accounting year and is not in EPA status 6 or 7,
- EPA status 7: CCI is not yet used in Annex 5 of any sent ACR of the previous accounting year or is used but in EPA status 6 or 7.

In other words:

Previous accounting year	Possible EPA statuses for current accounting year
1	2, 3, 4, 5, 6
2	2, 3, 4, 5, 6
3	2, 3, 4, 5, 6
4	3, 4, 5, 6
5	3, 4, 5, 6
6	1, 7
7	1, 7

(2) Click on **SAVE** to save the information.

	Depending on the EPA status selected, an “Add arrangement” field is foreseen:							
	<table border="1"> <thead> <tr> <th>Arrangements applied</th> <th>1.1. Does managing authority rely on verifications carried out by competent external body/bodies? *</th> <th>1.1.1. Name(s) of the body/bodies *</th> <th></th> </tr> </thead> <tbody> <tr> <td colspan="4" style="text-align: center;"><i>No arrangements added yet</i></td> </tr> </tbody> </table> <div style="border: 1px solid black; padding: 5px; width: fit-content;">Please select an arrangement ▼</div>	Arrangements applied	1.1. Does managing authority rely on verifications carried out by competent external body/bodies? *	1.1.1. Name(s) of the body/bodies *		<i>No arrangements added yet</i>		
Arrangements applied	1.1. Does managing authority rely on verifications carried out by competent external body/bodies? *	1.1.1. Name(s) of the body/bodies *						
<i>No arrangements added yet</i>								
REMARK	<p>The “Add arrangement” list contains all not yet selected Arrangements valid for the CCI and EPA status and is active for EPA statuses 1 and 3.</p> <p>Under EPA status 2, the “Add arrangement” list is disabled because all Arrangements for the selected CCI are automatically copied from any ACR of the previous accounting year and cannot be modified.</p> <p>When adding Arrangement 1, column 1.1 is enabled and becomes mandatory. When selecting “Yes” in column 1.1, column 1.1.1 (maximum size of 500 characters, blanks excluded.) is enabled and becomes mandatory.</p> <p>Under EPA status 3, the “Add arrangement” list contains all not yet selected Arrangements valid for the CCI and EPA status. Newly added Arrangements for the CCI, compared to the previous accounting year is marked as NEW.</p> <p>Under EPA statuses 4 to 5, a free text input field is foreseen with a maximum size of 10000 characters, blanks excluded.</p>							

Validate the Annual Control Report (EMFAF)

REMARK	<p>The Annual Control Report can be validated at any time, when the current version is in status OPEN and resides at the User’s Node.</p> <p>To validate the Annual Control Report, the User must have the role of MS Audit Authority with Update access (MSAAu).</p>
---------------	--

Click on the **VALIDATE** button to validate the Annual Control Report:

ACR-EMFAF list ACR - Test SG - 2021.0

2021.0 IT01 08/02/2023, 14:34 OPEN Validate

Table of Contents < GENERAL

Version information ⓘ Edit

Title	Version	Last modified	Current node
ACR - Test SG	2021.0	08/02/2023, 14:34	Abruzzo

Source language
English

REMARK	An ERROR will block you from sending the Annual Control Report. The error(s) should be resolved and the Annual Control Report must be revalidated. Note that a WARNING does not block you from sending the Annual Control Report.
---------------	---

The system validates the following information:

Code	Severity	Validation Rule
001	WARNING	Validate that at least one official in charge of the Member State exists.
002	ERROR	Validate that the CCI codes of the adopted programmes match the following regular expression: For EMFAF (.....14MFPR...) (Implicit in web).
003	WARNING	Validate that the current date is <= 15th of February accounting year + 2 (Implicit in web).
004	ERROR	Validate that the annual control report version covers at least one programme.
005	ERROR	Validate that the “annual control report” document (ACR.ACR) is uploaded when no previous annual control report version exists or when requested in the previous annual control report version.

006	ERROR	Validate that all integral documents have at least one attachment with a length > 0.
007	ERROR	Validate in annex 1, when a record has one of the essential key requirements (KRs: 2, 4, 5, 9) or two or more of the other key requirements classified in category 3 or 4, that this record cannot have an overall assessment better than category 3 or 4.
008	ERROR	Validate in annex 1 that only programme(s) are used that are covered by the annual control report (Implicit in web).
009	ERROR	Validate in annex 1, that the Fund(s) belong to the programme(s) specified in the annex 1 table record (Implicit in web).
010	ERROR	Validate in annex 1, that the key requirements are valid for the entity type (Implicit in web).
011	ERROR	Validate in annex 1, that the entity type is "Managing Authority" or "Body (other than the managing authority) carrying out the accounting function" (Implicit in web).
012	ERROR	Validate in annex 1, that for each record at least one CCI and one Fund is selected.
013	ERROR	Validate in annex 1, that each selected key requirement has a category indication (Implicit in web).
014	WARNING	Validate in annex 1, that at least 1 record exists with at least 1 key requirement selected.
015	ERROR	Validate in annex 1, that there are no duplicate combinations of CCI(s), Fund(s), authority type, audited entity, title of the audit, date of the final audit report.
016	ERROR	Validate that the programmes covered, only exist in one non-cancelled annual control report of the same year and with the same annual control report ID.
017	ERROR	Validate in annex 1 that the date of final audit report is <= current date.
018	WARNING	Validate in annex 1 that each record exists as a NAR object by cross checking the CCI(s)/Fund(s)/audited entity/date of final audit report combination between ACR and NAR.
019	ERROR	Validate in annex 2 that only programme(s) are used that are covered by

		the annual control report (Implicit in web).
020	ERROR	Validate in annex 2, that the Fund(s) belong to the programme(s) specified in the annex 2 table record (Implicit in web).
021	ERROR	Validate in annex 2, that for each record at least one CCI and one Fund is selected.
022	ERROR	Validate on working version 0 for accounting versions > 2021 that a "Calculation random sample selection (Spreadsheet format)" (ACR.CRS) was uploaded. For consecutive versions, it is not mandatory to upload this document.
023	WARNING	Validate that when a "Calculation random sample selection (Spreadsheet format)" (ACR.CRS) was uploaded, that its file type/mime type is for spreadsheets.
024	WARNING	Validate that there is at least 1 record in annex 4 on audit findings.
025	ERROR	Validate in annex 4, that the Fund belongs to the programmes covered by the annual control report (Implicit in web).
027	ERROR	Validate in annex 5 when arrangement 1 is selected that 1.1 has an answer.
028	ERROR	Validate in annex 5 when arrangement 1 is selected and the answer to 1.1 is "Yes", that 1.1.1 is not empty.
029	ERROR	Validate in annex 5 for each of the EPA statuses 1, 2 and 3, that at least one arrangement is selected.
030	ERROR	Validate in annex 5 for each of the EPA statuses 4 and 5, that a free text is provided.
031	ERROR	Validate in annex 5 for EPA status 1 records, that the CCI is covered by the ACR and was not yet used in the annex 5 of any sent ACR of the previous accounting year or was used but only in EPA status 6 or 7.
032	ERROR	Validate in annex 5 for EPA status 2 records, that the CCI is covered by the ACR and was already used in the annex 5 of the sent ACR of the previous accounting year with an EPA status different from 4, 5, 6 or 7.
033	ERROR	Validate in annex 5 for EPA status 2 records, that arrangements applied are identical to the arrangements applied for the same CCI in the ACR of the previous accounting period (Implicit in web).

034	WARNING	Validate in annex 4 that “Cases of suspected fraud” is <= “Frequency (number of cases) “.
035	WARNING	Validate in annex 4 that “Cases of gold plating” is <= “Frequency (number of cases) “.
036	ERROR	Validate on working version 0 for accounting versions > 2021 that a “Calculation of total error rate (Spreadsheet format)” (ACR.TER) was uploaded. For consecutive versions, it is not mandatory to upload this document.
037	WARNING	Validate that when a “Calculation of total error rate (Spreadsheet format)” (ACR.TER) was uploaded, that its file type/mime type is for spreadsheets.
038	ERROR	Validate on working version 0 for accounting versions > 2021 that a “Calculation of total residual error rate (Spreadsheet format)” (ACR.TRR) was uploaded. For consecutive versions, it is not mandatory to upload this document.
039	WARNING	Validate that when a “Calculation of total residual error rate (Spreadsheet format)” (ACR.TRR) was uploaded, that its file type/mime type is for spreadsheets.
040	ERROR	Validate in annex 5 for each of the EPA statuses 3 to 6 records, that the CCI is covered by the ACR and was already used in the annex 5 of the sent ACR of the previous accounting year with an EPA status different from 6 or 7.
041	ERROR	Validate in annex 2 that the ‘Residual total error rate’ (column F) is <= 2%.
042	ERROR	Validate in table 4, for sub-categories with ‘Other’, that details about the findings are provided in the “Comments” column (Implicit in web).

An example of a validation window:

Latest validation result



 The Annual Control Report version has been successfully validated

You can check the list of validation results at any time throughout the Annual Control Report:

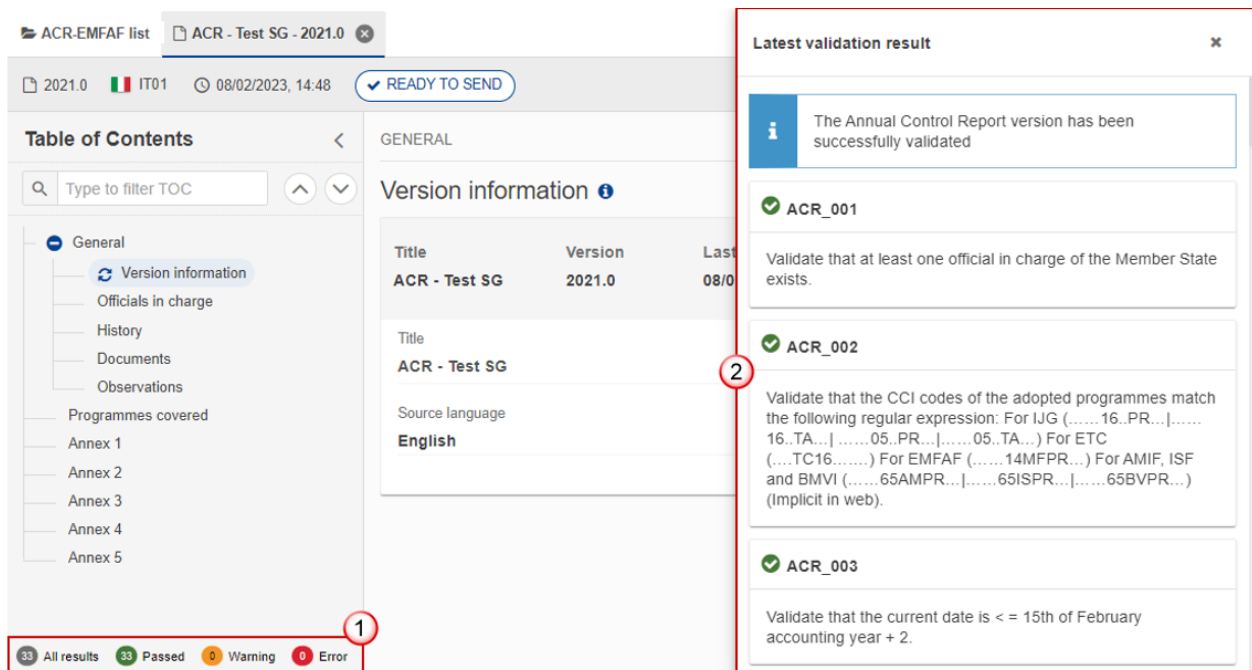

The screenshot shows the 'ACR-EMFAF list' interface for 'ACR - Test SG - 2021.0'. The main area displays 'Version information' with a table:

Title	Version	Last
ACR - Test SG	2021.0	08/0

Below the table, the source language is listed as 'English'. A 'Table of Contents' sidebar is visible on the left. At the bottom, a status bar shows '33 All results', '33 Passed', '0 Warning', and '0 Error'. A red circle '1' highlights this status bar. A 'Latest validation result' pop-up window is open on the right, showing a success message and a list of three validation rules:

- ACR_001**: Validate that at least one official in charge of the Member State exists.
- ACR_002**: Validate that the CCI codes of the adopted programmes match the following regular expression: For IJG (.....16..PR...|.....16..TA...|.....05..PR...|.....05..TA...) For ETC (...TC16.....) For EMFAF (.....14MFPR...) For AMIF, ISF and BMVI (.....65AMPR...|.....65ISPR...|.....65BVPR...) (Implicit in web).
- ACR_003**: Validate that the current date is <= 15th of February accounting year + 2.

A red circle '2' highlights the list of validation rules in the pop-up window.

To see the last validation results:

- (1) Click on one of the 4 categories: *All results*, *Passed*, *Warning*, *Error*.
- (2) The list of latest validation results for the chosen category is displayed.

After all errors have been resolved the status of the Annual Control Report becomes **VALIDATED**.

Prepare the Annual Control Report (EMFAF) for send to EC

REMARK	<p>The Prepare for Send can occur when a User on the highest MS Node wants to indicate that the Annual Control Report version can be prepared for sending to the Commission, once the VALIDATION ERRORS have been removed and the status is VALIDATED or SENT.</p> <p>To prepare the send of the Annual Control Report, the User must have the role of MS Audit Authority with Update or Send access (MSAAu/s).</p>
---------------	---

1. Click on the **PREPARE FOR SEND TO EC** button to prepare to send the Annual Control Report to the Commission:

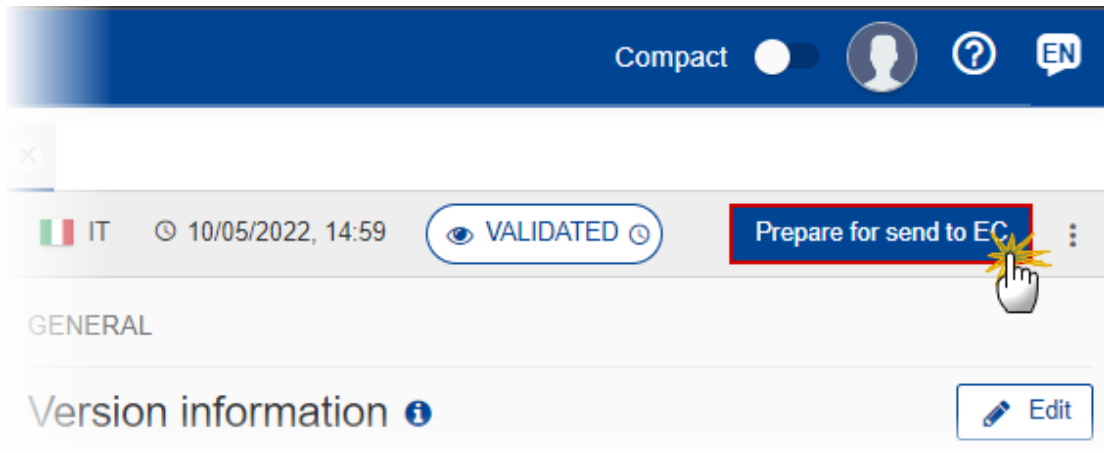

The system will ask you to confirm the send action:

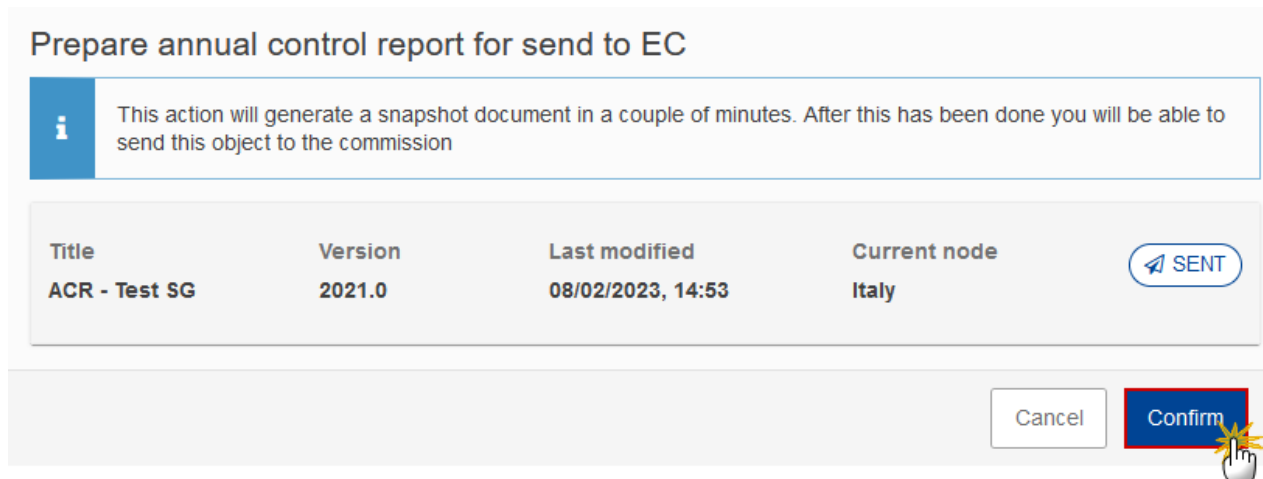

2. Click on **CONFIRM** to confirm.

The status of the Annual Control Report is set to **PREPARING FOR SEND TO EC**.

Send the Annual Control Report (EMFAF)

REMARK	<p>The Annual Control Report can only be sent to the Commission or to an upper Node once the VALIDATION ERRORS have been removed and the status is READY TO SEND or SENT. A notification will be sent to notify the Commission or the upper Node of the sending of the version.</p> <p>The "4 eyes principle" must be respected. Therefore, the User sending must be different from the User who last validated.</p> <p>To send the Annual Control Report, the User must have the role of MS Audit Authority with Send access (MSAAs).</p>
---------------	---

1. Click on the **SEND** button to send the Annual Control Report to the Commission or to the upper Node:

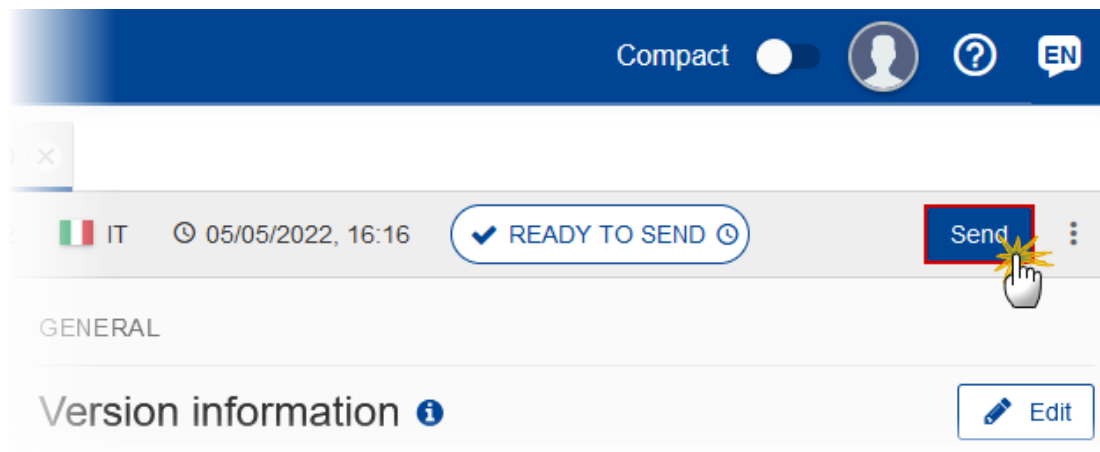

The system will ask you to confirm the send action:

Send annual control report

Title	Version	Last modified	Current node	<input checked="" type="button" value="READY TO SEND"/>
ACR - Test SG	2021.0	08/02/2023, 14:48	Abruzzo	

2. Click on **CONFIRM** to confirm.

On success, the Annual Control Report version has been sent to the Commission or to the upper Node. When sent, the status is set to **SENT**.

REMARK	<p>When on the highest MS node, different versions of the generated “Snapshot before send” document will be available so that the sender can first verify what will be sent to the Commission:</p> <ul style="list-style-type: none">• A version containing the untranslated content with the template in the Source language.• When the Source language is different from English, a version containing the untranslated content with the template in English.• When the Source language is different from English, a version containing a machine translation of the content in English with the template in English.
---------------	---

Return the Annual Control Report (EMFAF) for modification by MS

REMARK	<p>The Annual Control Report can only be returned by MS for modification when a lower Node exists and the status is SENT (to a higher MS node), OPEN, VALIDATED, READY TO SEND or RETURNED BY MS FOR MODIFICATION.</p> <p>This action can be used when a User wants to return the Annual Control Report version sent by the Member State/Region because it is incomplete or incorrect.</p> <p>To request the return of an Annual Control Report version, the User must have the role of MS Audit Authority with Update access (MSAAu).</p>
---------------	---

Follow the steps to return the Annual Control Report for modification by MS:

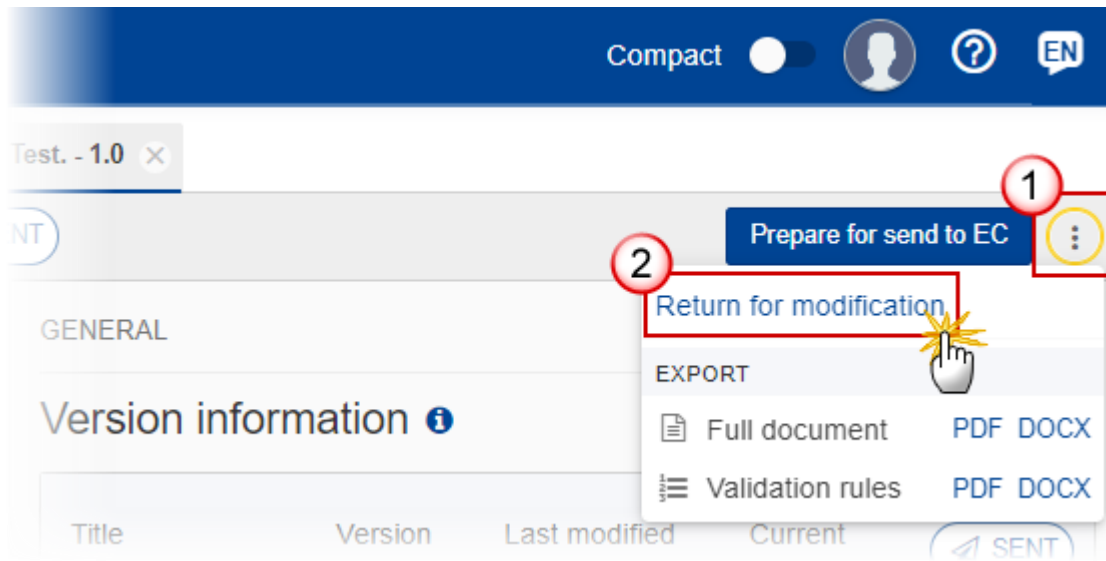

1. Select the following:

(1) Select the icon with 3 vertical dots.

(2) Click on the **RETURN FOR MODIFICATION** button to request revision from the lower Node.

The system will ask you to confirm the return:

Return for modification by MS

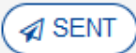
Title	Version	Last modified	Current node	
ACR - Test SG	2021.0	08/02/2023, 14:53	Italy	

Reason for return *

Reason...







1. Enter the following:

- (1) Enter the *Reason for return* in the text box provided.
- (2) Click on **CONFIRM** to save the information.

On success, the status of the Annual Control Report will be changed to status **RETURNED BY MS FOR MODIFICATION** and the sender is notified of the action and its reason.

Delete the Annual Control Report (EMFAF)

REMARK	<p>The Annual Control Report can only be deleted when:</p> <ul style="list-style-type: none"> • it resides on the owner Node • the status is OPEN, VALIDATED or READY TO SEND or RETURNED BY MS FOR MODIFICATION • it has never been sent to the Commission before • it has no sent documents attached. <p>To delete the Annual Control Report, the User must have the role of MS Audit Authority with Update access (MSAAu).</p> <p>The delete is a physical delete and cannot be recovered!</p>
---------------	--

Follow the steps to remove the Annual Control Report from the system:

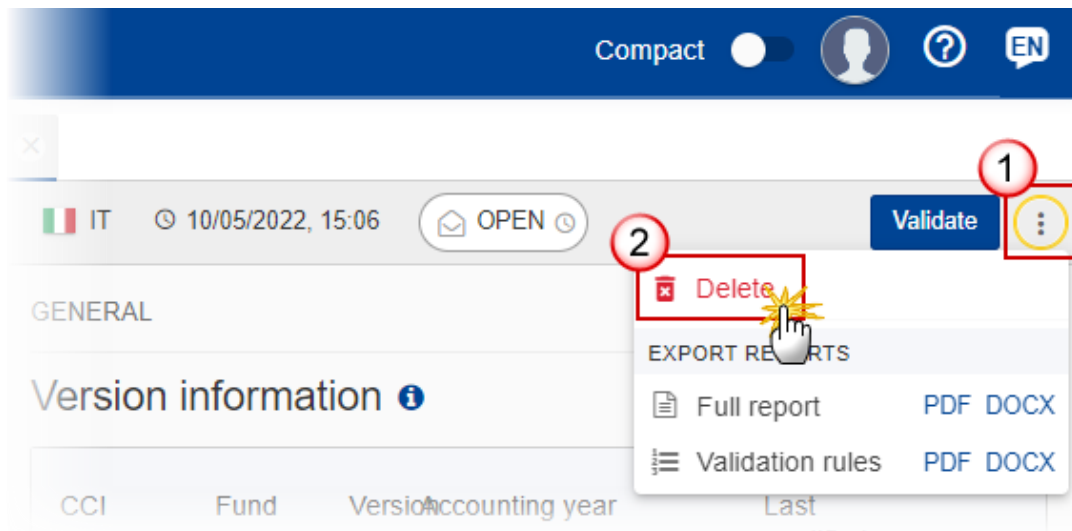

1. Select the following:

- (1) Select the icon with 3 vertical dots.
- (2) Click on the **DELETE** button to remove the Annual Control Report from the system.

The system will ask you to confirm the delete action:

Delete annual control report

Title	Version	Last modified	Current node	
ACR - Test SG	2021.0	24/01/2023, 15:01	Abruzzo	 OPEN

Cancel **Confirm**



- Click on **CONFIRM** to confirm or click on **CANCEL** to return to the Annual Control Report.

Cancel the Annual Control Report (EMFAF)

REMARK	<p>Once the Annual Control Report or one of its non-integral documents have been sent to the Commission, it cannot be deleted anymore when returned by the Commission. For Member States who don't want to continue working on that Annual Control Report and who want to create one or more new ones, an action Cancel is foreseen. A notification will be sent to notify the cancel by the Member State to the Commission.</p> <p>The Annual Control Report version must currently reside on the User's Node and its status is OPEN, VALIDATED, READY TO SEND or REVISION REQUESTED BY MS and contains a sent Document.</p> <p>To cancel an Annual Control Report version, the User must have the role of MS Audit Authority with Update access (MSAAu).</p>
---------------	---

Follow the steps to cancel the Annual Control Report from the system:

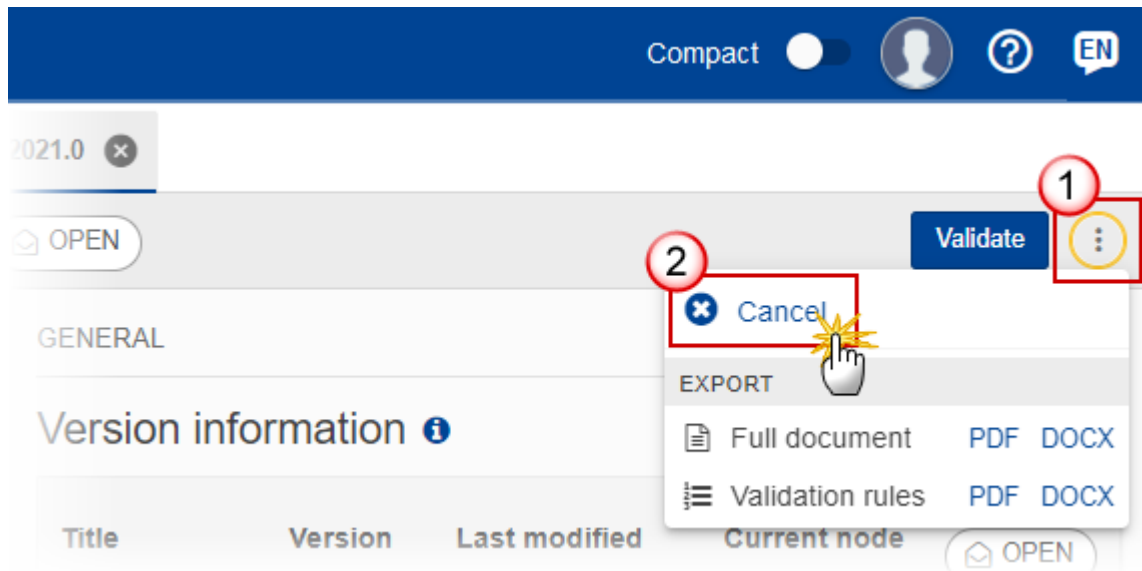

1. Select the following:

- (1) Select the icon with 3 vertical dots.
- (2) Click on the **CANCEL** button to cancel the Annual Control Report from the system.

The system will ask you to confirm the cancel action:

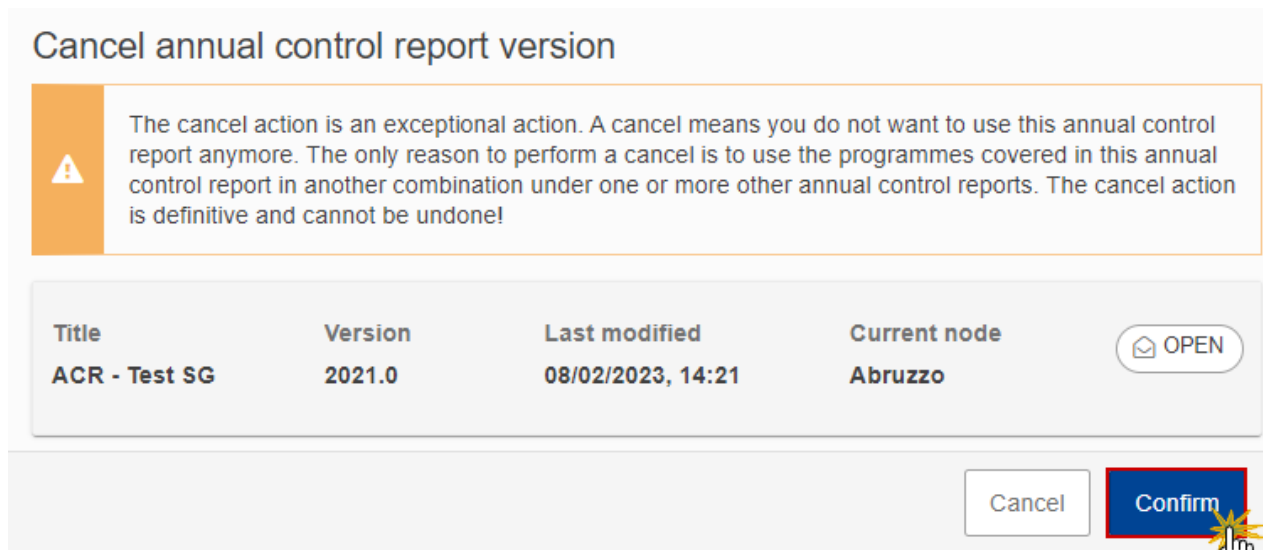

2. Click on **CONFIRM** to confirm or click on **CANCEL** to return to the Annual Control Report.

On success, the status of the Annual Control Report will be changed to **CANCELLED**.

Create a New Version of the Annual Control Report (EMFAF)

REMARK	<p>A new version of the Annual Control Report needs to be created when on the last version was assessed by the Commission with observations or returned by the Commission for modification, and at least one element was set to be modified by the MS.</p> <p>A new version of the Annual Control Report can only be created when the last of the Annual Control Report is in status ASSESSED BY EC (OBSERVATIONS) or RETURNED BY EC (IMMATERIAL OR CLERICAL ERRORS) or RETURNED BY EC, and at least one element was set to be modified by the MS.</p> <p>To create a new version of an Annual Control Report, the User must have the role of MS Audit Authority with Update access (MSAAu).</p>
---------------	--

1. Click on the **CREATE** button to create a new version of the Annual Control Report:

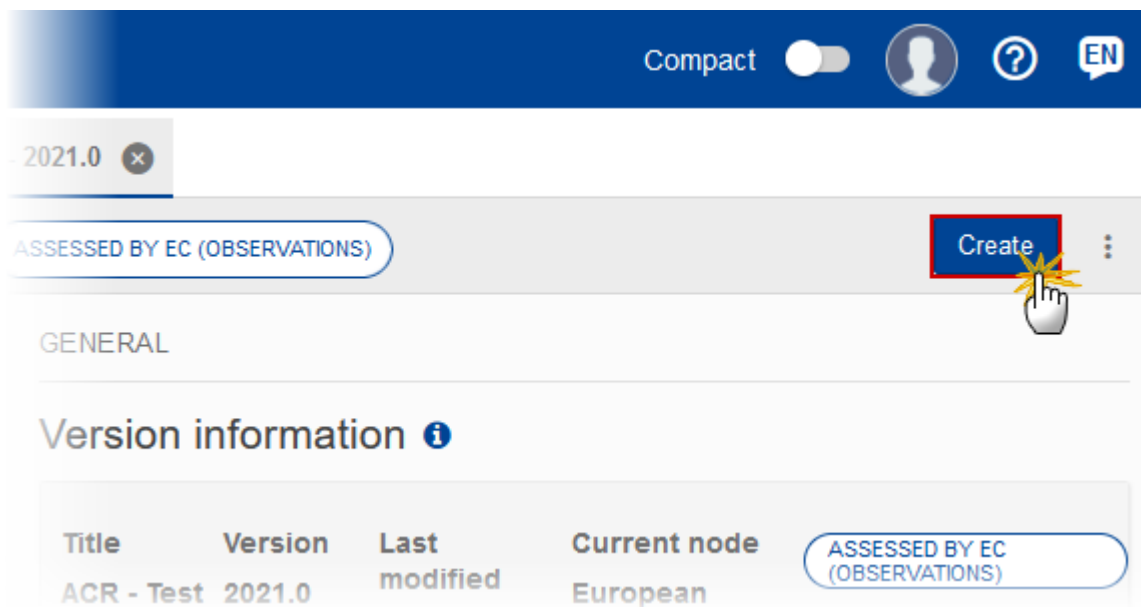

The system will ask you to confirm the creation of a new version:

Create new annual control report

Title	Version	Last modified	Current node
ACR - Test SG	2021.0	08/02/2023, 15:52	European Commission

ASSESSED BY EC (OBSERVATIONS)

Cancel

Confirm



2. Click on **CONFIRM** to confirm. Click on **CANCEL** to return to the Annual Control Report.

On success, a new version of the Annual Control Report has been created as a copy of the last version, with a version number identical to the previous and a working version number incremented by one. Its status is set to **OPEN**.